

INTEGRATED, 2-IN-1 CATALYST CHARACTERIZATION SYSTEM WITH FLOW (TCD) AND VACUUM VOLUMETRIC TECHNIQUES

Autosorb[®]-1-C/TCD Benefits

- Combines gas detection by high sensitivity, thermal conductivity detector (TCD) for TPR/TPD/TPO analysis and automatic physisorption and chemisorption by precise vacuum volumetric method for analysis of BET surface area, meso- and micropore size distribution, active surface area, degree of metal dispersion, heats of adsorption, etc.
- Temperature programmed techniques (TPR/TPD/TPO) automatically performed via user programmable pre-treatment and analysis procedures including multi-step temperature ramping up to 1,100 deg C, automatic gas switching and automated data acquisition.
- Also provides for flow-based, pulse titration method for rapid determination of active surface area, degree of metal dispersion, etc.
- Available vapor generator option with heated manifold for use with water and organic vapors.
- Available, integrated mass spectrometer option for identification of desorbed gases.

The active surface of many catalysts is often found deep within pores of individual particles. This fact has a tremendous impact on catalyst performance because, even for a single solid, not all surfaces are created equal. Real surfaces are heterogeneous and their properties vary from exterior to interior as well as from one surface site to another. Textural (surface area, pore size and pore volume) properties and surface reactivity / heterogeneity can most fully be quantified and qualified by means of a complete gas sorption analyzer such as the Autosorb-1-C with TCD option.

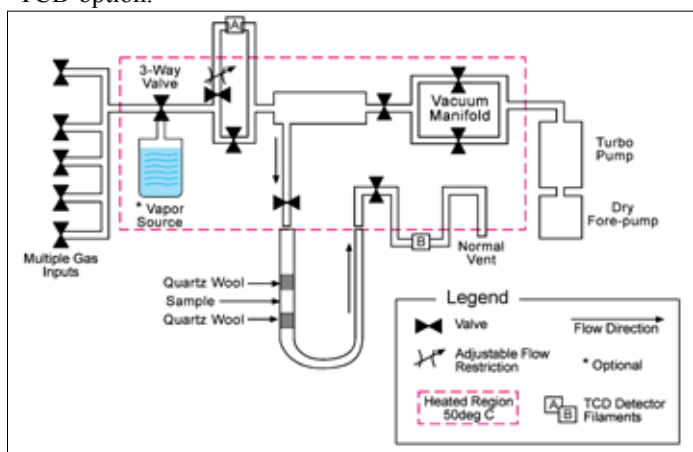

AUTOSORB[®]-1-C/TCD



Temperature Programming

During a chemisorption analysis, the total number of active sites, or the active surface area, is evaluated. However, if one heats up the sample, the chemisorbed species tend to desorb according to how strongly they were bound to the active sites. Weaker sites normally release their chemisorbed species at lower temperatures than stronger sites.

If the sample had two distinct types of active sites, heating would release gases at two different temperatures. To quantify these released gases, one can increase the sample temperature linearly and monitor the desorption of gases with a high sensitivity thermal conductivity detector - the so-called TPD method. The reduction behavior of dispersed metal catalysts can be characterized by monitoring the rate at which a reducing gas (typically H₂ or CO) reacts as a function of temperature - the so-called TPR method. Similarly, the oxidation behavior can be characterized by flowing O₂ and tracking reaction rate with temperature - the so-called TPO method.

The Autosorb-1-C with TCD option provides for TPD, TPR and TPO analysis as well as complete active surface area, BET surface area and micro-/mesopore size analysis for comprehensive catalyst characterization.

Key Features

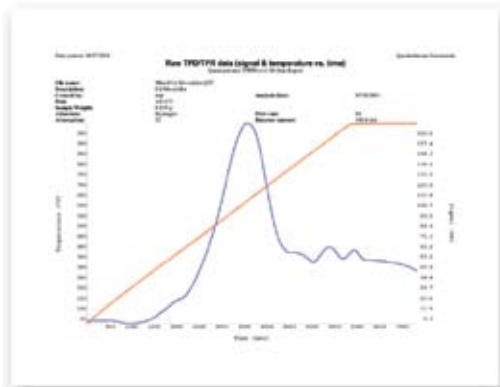

Hydrogen TPR of mixed Cu/Mo oxides.

- Switch from vacuum volumetric analysis to temperature-programmed, flow-based TCD analysis in less than 1 minute.
- Windows® based data acquisition for both vacuum volumetric and flow-based TCD measurement modes.
- Performs both quantitative and qualitative analysis of active sites in catalysts.
- Performs low pressure gas sorption analysis for characterization of micropore size distribution in zeolites, activated carbons, silicas, etc.
- Fully programmable gas switching and temperature ramping for maximum experimental versatility.

Autosorb-1-C/TCD Specifications for TPR/TPD/TPO

(TCD performance specifications - see Autosorb-1 brochure for full vacuum volumetric performance specifications)

Gas volume range:	1 x10 ⁻³ cc to > 1 x10 ² cc
Reproducibility:	typically better than 0.5%
Sensitivity:	10 positions (dynamic range: 512) plus user selectable detector current
TPR/TPD heating rates:	1°C/min to 100°C/min (up to 500°C) 1°C/min to 50°C/min (up to 750°C) 1°C/min to 30°C/min (up to 1000°C) 1°C/min to 20°C/min (up to 1100°C)
Furnace controller:	PID, featuring auto-tuning
Sample thermocouple:	positioned alongside sample
TCD filament:	tungsten-rhenium, diffusion-type, oxidation resistant
Electrical:	90 - 240 VAC, 50/60Hz
Operating environment:	20 - 80% RH, 15° to 35° C



Side-arm cell with injection port for (i) pulse titration by syringe injection, (ii) calibrating loop volumes and (iii) rapid saturation with liquids (e.g. pyridine) prior to TPD.

Optional Loop Injection Assembly

For convenient pulse titration method of determining metal area, dispersion and crystallite size. Conveniently mounts on the side of the Autosorb-1. Features quick-connect gas fitting for the titration gas for rapid switching between different active gases, and front-mounted calibration ports. Includes one each of 50, 100 and 250-microliter loops.



Optional Cold Trap Assembly

For “clean” TPR signals by preventing moisture from reaching TCD detector. Complete with bypass valve and adjustable height dewar. Also recommended for copper metal area determinations by N₂O titration.



Quantachrome Instruments' corporate headquarters in Boynton Beach, Florida.

Quantachrome®

Renowned innovator of ideas for today's porous materials community.

For almost 40 years, Quantachrome's scientists and engineers have revolutionized measurement techniques and designed instrumentation to enable the accurate, precise, and reliable characterization of powdered and porous materials:

- Adsorption/Desorption Isotherms
- Surface Area Measurement
- Pore Size Distribution
- Chemisorption Studies
- Water Sorption Behavior
- Mercury Porosimetry
- True Solid Density
- Tapped Density

Not only are Quantachrome products the instruments of choice in academia, but the technology conceived and developed by our expert staff is applied in industrial laboratories worldwide, where research and engineering of new and improved porous materials is ongoing. Manufacturers also rely on porous materials characterization technology to more precisely specify bulk materials, to control quality, and to isolate the source of production problems with greater efficiency.

Quantachrome is also recognized as an excellent resource for authoritative analysis of your samples in our fully equipped, state-of-the-art powder characterization laboratory.



Quantachrome Instruments Application Laboratory.

CORPORATE HEADQUARTERS

Quantachrome Instruments

1900 Corporate Drive
Boynton Beach, FL 33426 USA
Phone: +1 (561) 731-4999
Fax: +1 (561) 732-9888
E-mail: qc.sales@quantachrome.com

CHINA

Quantachrome Representative Office

M806. Jingbao Garden
183 Andingmenwai Street
Beijing 100011, China
Tel/Fax: +86 10 64400892

EUROPE

Quantachrome UK Limited

Pale Lane Farm, Pale Lane
Hartley Wintney
Hook RG27 8BA, UK
Phone: +44 (0) 1252819719
Fax: +44 (0) 1252819901

EUROPE

Quantachrome GmbH & Co. KG

Rudolf-Diesel Str. 12
85235 Odelzhausen, Germany
Phone: +49 (0) 8134/93240
Fax: +49 (0) 8134/932425



Quantachrome Instruments' quality management system is certified to be in accordance with ISO9001:2000.

WORLDWIDE SALES AND SERVICE

Argentina	Mexico
Australia	Middle East
Austria	Morocco
Bahrain	Netherlands
Belarus	New Zealand
Belgium	Norway
Brazil	Oman
Bulgaria	Pakistan
Canada	Peru
Central America	Philippines
Chile	Poland
China	Portugal
Colombia	Puerto Rico
Croatia	Romania
Cyprus	Russia
Czech Republic	Saudi Arabia
Denmark	Singapore
Egypt	Slovak Republic
Estonia	Slovenia
Finland	South Africa
France	South Korea
Germany	Spain
Greece	Sri Lanka
Hungary	Sweden
India	Switzerland
Indonesia	Taiwan
Ireland	Tanzania
Israel	Thailand
Italy	Turkey
Jamaica	Ukraine
Japan	United Arab Emirates
Jordan	United Kingdom
Kuwait	Uruguay
Latin America	Uzbekistan
Latvia	Venezuela
Lithuania	Vietnam
Malaysia	

Quantachrome
INSTRUMENTS

Serving Porous
Materials and Powder
Characterization
Needs Since 1968



www.quantachrome.com

Trademarks and registered trademarks are the property of their respective owners.